

## the Moderator

You may already be aware that Atkins has purchased EnergySolutions' Projects, Products and Technology (PP&T) division. The PP&T division includes the Training and Development organization personnel who teach the courses you or your colleagues have attended in the past. The transition should be seamless and everything that you value and appreciate about our transportation and motor carrier classes will remain unaffected. As we are still finalizing branding and a few

other matters, we wanted you to be aware that we are beginning to use the rebranded materials in our classes.

Registration for classes currently remains on the same [website](#), while our new website, [www.atkinsglobal.com/energytraining](http://www.atkinsglobal.com/energytraining) is under construction. Either address will redirect you to the website where you can register. Please bookmark the new Atkins web address for future reference. The website construction is scheduled to be finished in late May/early June.

If you have had correspondence with our training team recently, you may have received an automated e-mail reply announcing our new e-mail addresses. During this transition time, we have access to both Atkins and EnergySolutions e-mail. Please note the Atkins addresses and save them in your contacts for future use. We have been advised that our phone numbers will be changing as well, but for now our current ones are still active. Feel free to contact us!

Here are some e-mail addresses you may want to update:

Merrie Schilperoort – [Merrie.Schilperoort@atkinsglobal.com](mailto:Merrie.Schilperoort@atkinsglobal.com) (509) 375-9504

Jennifer Keszler – [Jennifer.Keszler@atkinsglobal.com](mailto:Jennifer.Keszler@atkinsglobal.com) (509) 375-9507

Nancy Strong -- [Nancy.Strong@atkinsglobal.com](mailto:Nancy.Strong@atkinsglobal.com) (803) 758-1882

Lauren Koon – [Lauren.Koon@atkinsglobal.com](mailto:Lauren.Koon@atkinsglobal.com) (803) 758-1887

Kevin Loomis – [Kevin.Loomis@atkinsglobal.com](mailto:Kevin.Loomis@atkinsglobal.com) (509) 375-9804

Brad Scott -- [Brad.Scott@atkinsglobal.com](mailto:Brad.Scott@atkinsglobal.com) (509) 375-9515

Julie Waddoups – [Julie.Waddoups@atkinsglobal.com](mailto:Julie.Waddoups@atkinsglobal.com) (509) 375-9553

Steve Anglesey – [Steve.Anglesey@atkinsglobal.com](mailto:Steve.Anglesey@atkinsglobal.com) (509)375-9508

We are excited about these changes and look forward to seeing you in class soon.

## FAA Enforcement is Trending Skyward

In August 2015, an article was written in the Dallas Morning News by Terry Maxon about the Federal Aviation Administration (FAA) cracking down on Hazardous Material Shippers<sup>1</sup>. The article raised some points that should garner attention, raise awareness, and cause action.

In 1996, the famous ValuJet incident occurred when oxygen generators stored in the cargo hold overheated and contributed to a fire that caused the jet to crash into the Florida everglades and kill all 110 people on board. Subsequently, there have been other incidents attributed to transporting oxygen generators and other hazardous materials in aircraft that have had unfortunate consequences. In 2010, a UPS plane crashed in Dubai killing both pilots due to a fire caused by lithium batteries.

A lot of changes have occurred in the regulations regarding the transport of lithium batteries and other hazardous materials since then. With changes in the law, enforcement follows.

The increase in enforcement is notable not only in time, but in cost. From 2010-12, the FAA assessed a total of \$5 million in civil penalties. In 2013 there were no penalties recorded. However, in 2014 a total of \$3.4 million were handed out and in 2015, through August alone, \$4.5 million had been assessed against nearly 3 dozen companies. United Airlines alone had a total of 120 alleged violations with penalties totaling of 1.3 million dollars.

These penalties were due to the improper shipment of hazardous materials. A quote from Lynn Lunsford who is a spokesman for the FAA was included in the article which stated "Almost all of the alleged violations

involved failing to provide the pilot in command with accurate information about hazardous materials aboard the aircraft, including the location of the materials on the aircraft; the materials' type, quantity, weight, proper shipping name, identification number and hazard class; dates of the flights; and confirmation that no damaged or leaking packages had been loaded onto the aircraft,". He went on to say, "A common denominator tends to be that the person doing the shipping did not receive adequate training on how to adequately package and identify the material".

<sup>1</sup><http://www.dallasnews.com/business/airline-industry/20150816-faa-cracks-down-on-hazardous-materials-shippers.ece>

## Proposed Rule Making Changes

There are some important proposed rule making changes still under consideration that motor carriers are keeping an eye on (refer to Federal Register, Vol. 80, No. 194, October 7, 2015, pages 60592 - 60601):

**Section 393.5, Definition of "Major Tread Groove"** – Currently, 393.75 specifies taking measurements for the 4/32 inch (front wheels) and 2/32 inch (all other wheels) at any point on a "major tread groove" and not where tire bars, humps or fillets are located. The term "major tread groove" is not defined and can be interpreted in different ways. The proposed definition, "the space between two adjacent tread ribs or lugs on a tire that contains a tread wear indicator or wear bar," would make measuring location more consistent. This change will prevent some tires from being disposed of before their time, thus, keeping unnecessary costs down.

## Section 393.11, License Plate Lights

– This is a proposal to modify the license plate light requirement on the rear of the commercial motor vehicle in states that do not require a rear license plate. As it stands now, the regulation of having a light on the rear license plate location means vehicles in such states have a lighted plate holder with no license plate to illuminate. If that light is not working or missing, a violation can be given even though there is not a state requirement for a license plate. Currently, only 14 states require a tractor to have a license plate on the front and the rear. Such change may prevent unnecessary roadside inspections and issuance of violations for a (defective or missing) light that is not needed.

## Part 396, Inspection, Repair, and Maintenance

– CVSA is proposing to remove their roadside inspection as equivalent to, and qualify as, an annual inspection. CVSA contends that their inspection is not intended to be equivalent to the "government mandated maintenance standard" and therefore should only serve to complement the required annual maintenance inspection program. They believe their roadside inspections do not provide the depth, or tools, to justify equivalency to the annual requirement, stating their inspection criteria "are neither suited nor intended to serve as vehicle maintenance or performance standards." Not getting annual inspection "credit" for CVSA roadside inspections will mean adhering to the more thorough annual inspection schedule - which should result in safer vehicles on the road.

## Severe Obstructive Sleep Apnea (OSA)

DOT is currently evaluating the need for medical screening of moderate- to-severe obstructive sleep apnea (OSA) among individuals performing safety sensitive functions. Public comments are being requested to help DOT determine OSA's potential consequences for the safety of rail and highway transportation, costs and benefits from regulatory actions that address OSA and the costs and benefits of requiring individuals who the trained medical professional believes are suffering from the effects of OSA to undergo evaluation and treatment. Many people who suffer from OSA may not even realize that they do. A person with OSA may actually only be getting the benefits of four hours of sleep when they thought they slept for eight hours. OSA disrupts the ability to breathe properly, thus, the airflow is obstructed and the sleeper will experience "respiratory effort-related arousals from sleep (RERAs)". Undiagnosed, DOT explains OSA can rob the sufferer of the deep sleep our bodies and minds need in order to perform safety sensitive functions in a safe manner. Lack of proper sleep can cause "deficits in attention, concentration, situational awareness, and memory, thus reducing the capacity to safely respond to hazards when performing safety sensitive duties." Untreated, DOT explains OSA can increase risk for: hypertension, (high blood pressure), diabetes, obesity, cardiac dysrhythmias (irregular heartbeat), myocardial infarction (heart attack), stroke, and sudden cardiac death. DOT is requesting comments to be submitted by June 8, 2016. Refer to Federal Register, Vol. 81, No. 47, pages 12642 – 12647.

## IATA DGR 2016 Second Update

International Air Transport Association (IATA) has published a 2nd addendum on 26 February 2016 for the 2016 Dangerous Goods Regulations (DGR) 57th edition. These regulations and updates in Addendum II are for shippers of dangerous goods (hazardous material) transported by air. This addendum contains new and amended provisions concerning lithium ion batteries, dry ice and radioactive material in Section 2.8.4 (Operator Variations) and Packing Instructions 965 & 968 in Section 5. These changes are effective as of 01 January 2016. Please download your own copy of these updates from IATA's download website <http://www.iata.org/whatwedo/cargo/dgr/Pages/download.aspx>

## 2016 Emergency Response Guidebook Available

The Pipeline and Hazardous Materials Safety Administration (PHMSA) Department of Transportation (DOT) has the new 2016 Emergency Response Guidebook (ERG) available for download from their website as a PDF and as an app for either Android or iPhone mobile devices. This manual is designed to help first responders in the Americas quickly identify emergency response procedures to deal with hazardous material transportation accidents during the critical first 30 minutes. Visit PHMSA's ERG webpage for more information at [www.phmsa.dot.gov/hazmat/outreach-training/erg](http://www.phmsa.dot.gov/hazmat/outreach-training/erg)

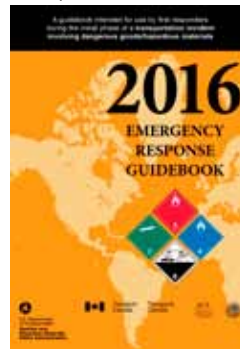

## DOT Restricts E-Cig Use on Aircraft

On May 19, 2016 (81 FR 31529), the Pipeline and Hazardous Materials Safety Administration (PHMSA) published a final rule in the federal register to prohibit passengers and crew members from carrying battery-powered portable electronic smoking devices (e.g., e-cigarettes, e-cigs, e-cigars, e-pipes, e-hookahs, personal vaporizers, electronic nicotine delivery systems) in checked baggage and from charging these devices and their batteries on board the aircraft. However, these devices may continue to be carried in carry-on baggage. This action is consistent with the interim final rule (IFR) published in the Federal Register (80 FR 66817) on October 30, 2015, and a similar amendment in the 2015–2016 Edition of the International Civil Aviation Organization Technical Instructions for the Safe Transport of Dangerous Goods by Air (ICAO TI). This final rule amends the Hazardous Materials Regulations (49 CFR Part 175) to maintain alignment with the ICAO TI. Furthermore, this final rule does not impact the existing rules on the transport of lithium batteries or other portable electronic devices that are transported for personal use in a passenger's checked or carry-on baggage. This final rule is effective June 20, 2016.



## Latest Happenings in the Federal Register

### Draft National Freight Strategic Plan

On March 10, 2016 (81 FR 12781), the Department of Transportation, Office of the Secretary published a notice in the federal register to request public comments on the draft National Freight Strategic Plan (NFSP) that includes: (1) an assessment of the conditions and performance of the National Freight Network; (2) an identification of bottlenecks on the National Freight Network that create significant freight congestion; (3) forecasts of freight volumes; (4) an identification of major trade gateways and national freight corridors; (5) an assessment of statutory, regulatory, technological, institutional, financial, and other barriers to improved freight transportation performance, including a description of opportunities for overcoming the barriers; (6) an identification of corridors providing access to energy exploration, development, installation, or production areas; (7) an identification of best practices for improving the performance of the National Freight Network; (8) an identification of best practices to mitigate the impacts of freight movement on communities; (9) a process for addressing multi state projects and encouraging jurisdictions to collaborate; and (10) strategies to improve freight intermodal connectivity. Comments must be received on or before April 25, 2016 to receive full consideration by DOT with respect to the final NFSP.

### NRC Requests 10 CFR Part 37 Comments

On March 14, 2016 (81 FR 13263), the Nuclear Regulatory Commission (NRC) published a notice in the federal register requesting general and specific comments on the overall effectiveness

and clarity of the requirements for security measures to protect category 1 and category 2 sources of radioactive material as defined in Appendix A to 10 CFR Part 37. For example, the NRC would like to gain insight on different regulatory requirements in 10 CFR Part 37 that may conflict or need to be modified to maximize effectiveness and provide greater clarification. The NRC is also requesting comments on the usefulness of the guidance documents associated with its regulations in 10 CFR Part 37. To facilitate comments, questions are listed in this federal register notice and categorized by the specific Subparts of 10 CFR Part 37: Subpart A—General Provisions; Subpart B—Background Investigations and Access Control Program; Subpart C—Physical Protection Requirements During Use; and Subpart D—Physical Protection in Transit. The NRC plans to hold a series of public meetings to facilitate public participation. These meetings will consist of a public meeting and a series of webinar teleconferences; and will be announced on the NRC's public meeting Web site at least 10 calendar days before the meeting. The NRC is planning to conduct these meetings in March of 2016. Please submit comments by May 13, 2016. Comments received after this date will be considered if it is practical to do so, but the NRC is able to ensure consideration only for comments received on or before this date.

### Volvo Trucks Safety Recall

On March 25, 2016 (81 FR 16264), the Federal Motor Carrier Safety Administration (FMCSA) published a notice in the federal register to inform the public it has determined that commercial motor vehicles manufactured by Volvo Trucks North America (Volvo Trucks) affected by the National Highway Traffic Safety

Administration (NHTSA) Part 573 Safety Recall Report No. 16V-097000 and have not already received the interim or permanent recall remedy repair specified by Volvo in the recall, are likely to cause an accident or breakdown because of a defective steering shaft which may disconnect from the junction block without warning, causing the vehicle to be in an unsafe condition. FMCSA is notifying commercial motor vehicle operators that vehicles subject to the recall without the interim or permanent repair will be subject to an immediate out-of-service order under 49 CFR 396.9 or compatible state regulations. This Notice is effective March 23, 2016.

### Recent Lessons Learned, Industry Events, Operating Experiences



Should all package markings be durable and able to survive normal conditions of transport like rain, sunlight, low and high temperature, wind, etc.? I hope you answered "YES!" This picture shows an EPA hazardous waste marking peeling off the surface of the package with a portion missing. EPA requires waste markings on non-bulk packages in accordance with 40 CFR 262.32. If you choose to place the marking on other packages, make sure it meets the durability and visibility requirements in 49 CFR 172.304.

## Latest Happenings in the Federal Register (cont.)

### Future Nuclear Waste Site Open Meeting

On March 28, 2016 (81 FR 17163), the Fuel Cycle Technologies, Office of Nuclear Energy, Department of Energy (DOE) published a notice in the federal register to invite the public to an open meeting that will be held in Atlanta, GA on April 11, 2016. The U.S. Department of Energy (DOE) is implementing a consent-based siting process to establish an integrated waste management system to transport, store, and dispose of spent nuclear fuel and high-level radioactive waste. In a consent-based siting approach, DOE will work with communities, tribal governments and states across the country that express interest in hosting any of the facilities identified as part of an integrated waste management system. As part of this process, the DOE is hosting a series of public meetings to engage communities and individuals and discuss the development of a consent-based approach to managing our nation's nuclear waste. The meeting will take place on Monday April 11, 2016 from 1:00 p.m. to 5:00 p.m. EDT. Informal poster sessions will be held from 12:00 p.m. until 1:00 p.m. EDT and again after 5:00 p.m. EDT. DOE officials will be available to discuss consent-based siting during the poster sessions.

### DOT Adopted Reverse Logistics

On March 31, 2016 (81 FR 18527), the Pipeline and Hazardous Materials Safety Administration (PHMSA) published a final ruling in the federal register to adopt regulatory amendments applicable to the reverse logistics shipments of certain hazardous materials by highway transportation. This final rule revises the Hazardous Materials Regulations (HMR) to include a definition of "reverse logistics" and provides appropriate provisions for hazardous materials within the scope of this definition. This final

rule also expands a previously existing exception for return shipments of used automobile batteries transported between a retail facility and a recycling center. The PHMSA incorporated recommendations from petitions for rule making and public comment into this rule making from both the Advance Notice of Proposed Rule making (ANPRM) published on July 5, 2012 [77 FR 39662] and the Notice of Proposed Rule making (NPRM) published on August 11, 2014 [79 FR 46748]. This final rule is effective on March 31, 2016.

### Lithium Battery Safety Advisory

On April 7, 2016 (81 FR 20443), the Pipeline and Hazardous Materials Safety Administration (PHMSA) published a Safety advisory notice in the federal register to inform persons engaged in the transport of lithium batteries in commerce of recent actions taken by the International Civil Aviation Organization (ICAO) to enhance the safe transport of lithium batteries by air. According to the International Coordinating Council of Aerospace Industries Association (ICCAIA), Boeing, and other aircraft manufacturers, the fire suppression capabilities of an aircraft may be exceeded in a situation where heat and flames generated from thermal runaway in a single package of lithium ion batteries spreads to adjacent packages, potentially leading to a catastrophic loss of the aircraft because of a fire that cannot be contained or suppressed. To minimize this risk, PHMSA has added: (1) A prohibition on the transport of lithium ion cells and batteries as cargo aboard passenger carrying aircraft (this prohibition applies to lithium cells and batteries (UN3480) not contained in or packed with equipment when transported as cargo and does not include batteries contained in personal electronic devices carried by passengers or crew);

(2) A requirement for lithium ion cells and batteries to be shipped at a state of charge of no more than 30 percent of their rated capacity on cargo aircraft (forbidden on passenger); and (3) A limit on the number of packages of both lithium ion and lithium metal batteries that may be offered for transportation on cargo aircraft under current provisions for small cells and batteries to not more than one package per consignment or overpack. These amendments are effective April 1, 2016.

### DOT Updates ASME Code

On April 29, 2016 (81 FR 25613), the Pipeline and Hazardous Materials Safety Administration (PHMSA) published a direct final rule in the federal register to incorporate by reference the most recent editions of the American Society of Mechanical Engineers (ASME) Boiler and Pressure Vessel Code in 49 CFR Parts 171, 173 & 178 of the Hazardous Material Regulations (HMRs). The purpose of this update is to enable non-specification (nurse tank) manufacturers and other DOT and UN specification packaging manufacturers to utilize current technology, materials, and practices to help maintain a high level of safety. PHMSA is replacing the ASME referenced standard (1998 Edition) with the new, current ASME standard (2015 Edition) for boiler and pressure vessels. PHMSA is also replacing the ASME 1998 Edition referenced standard of ASME's Transportation Systems for Liquids and Slurries: Pressure Piping to the current 2012 Edition. This final rule is effective June 28, 2016 without further action, unless adverse comment is received by May 31, 2016. If adverse comment or notice of intent to file an adverse comment is received, PHMSA will publish a timely withdrawal of the rule in whole or in part in the Federal Register before June 13, 2016.

## Latest Happenings in the Federal Register (cont.)

### DOT Issues CFR Correction

On April 25, 2016 (81 FR 24038), the Pipeline and Hazardous Materials Safety Administration (PHMSA) published a Code of Federal Regulations (CFR) correction in the federal register to add the letter "G" in the first column for the entry "Phenylmercuric compounds, n.o.s." on page 269 in the Hazardous Materials Table 49 CFR 172.101, revised as of October 1, 2015.

### DOT Proposes to Use 2015 ASME Code

On April 29, 2016 (81 FR 25627), the Pipeline and Hazardous Materials Safety Administration (PHMSA) published a Supplemental Notice of Proposed Rule making (SNPRM) in the federal register proposing to incorporate and allow the use of the 2015 edition of the American Society of Mechanical Engineers (ASME) Boiler and Pressure Vessel Code, Section XII - Rules for Construction and Continued Service of Transport Tanks for the construction and continued service of cargo tank motor vehicles (CTMVs), cryogenic portable tanks, and multi-unit tank car tanks ("ton tanks") in 49 CFR Parts 107, 171, 173, 178, 179 and 180. The PHMSA also proposes to incorporate and authorize the use of the 2015 edition of the National Board of Boiler and Pressure Vessel Inspectors National Board Inspection Code, in our regulations as it applies to the continued service of CTMVs, cryogenic portable tanks, and ton tanks constructed to ASME Section XII standards, as well as for existing CTMVs constructed in accordance with the current hazardous materials regulations. If adopted, these amendments will allow for flexibility regarding selection of authorized packaging, in addition to qualification and maintenance for continued service of the packaging,

without compromising safety. Please submit comments by June 28, 2016.

### Vessel Cargo Securing Manual Ruling

On May 9, 2016 (81 FR 27992), the Coast Guard (CG) published an interim rule and request for comment in the federal register to require U.S. and foreign self-propelled cargo vessels of 500 gross tons or more, traveling on international voyages and carrying cargo that is other than solid or liquid bulk cargo, to have cargo securing manuals (CSMs) on board. The rule also requires those vessels to comply with certain provisions of the International Convention for the Safety of Life at Sea, 1974 as amended (SOLAS), authorizes recognized classification societies or other approval authorities to review and approve CSMs on behalf of the Coast Guard; and prescribes when and how the loss or jettisoning of cargo at sea must be reported. The Coast Guard requests public comment on its intention to extend, in a subsequent final rule, this interim rule's requirement for vessel CSMs to self-propelled cargo vessels under 500 gross tons, if these vessels carry dangerous goods in packaged form on international voyages. This interim rule promotes the Coast Guard's maritime safety and stewardship (environmental protection) missions, helps fulfill U.S. treaty obligations, and could help prevent or mitigate the consequences of vessel cargo loss. This interim rule is effective June 8, 2016. Comments must be received by August 8, 2016. The incorporation by reference of certain documents in this rule is approved by the Director of the Federal Register as of June 8, 2016.

## Recent Lessons Learned, Industry Events, Operating Experiences

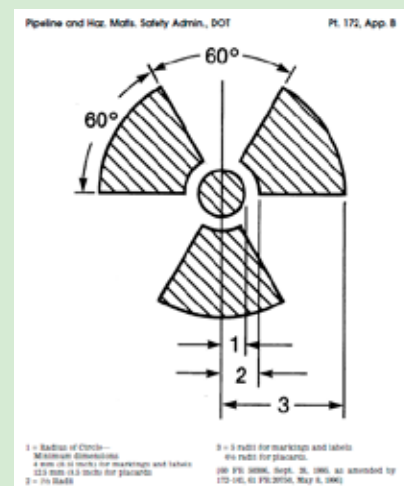

How many issues can you identify on this placard? Looking at the trefoil, does it match the allowed proportions authorized in Appendix B to 49 CFR Part 172 per 49 CFR 172.519(g)? The center dot is too big with little yellow space between the center and the blades. Also, does the package surface provide enough contrast to the placard color? If not, the placard will need either a dotted or solid line outer border to provide the needed contrast per 49 CFR 172.516(c)(7).

## Frequently Asked Questions

Our FAQ topic for this quarter looks at determining radioactive (Class 7) material.

**\* Can material containing radionuclides be shipped as class 7 material when both limits in 49 CFR 173.436 are not exceeded?**

**Reference # 09-0260, 06-0211, 06-0274, 11-0038**

No, both limits in 49 CFR 173.436 must be exceeded to classify a material as radioactive (class 7) material per the definition in 49 CFR 173.403.

**\* Is the definition of contamination in 49 CFR 172.403 used to determine if a material is class 7 (radioactive) material?**

**Reference # 06-0002R**

No, the definition of contamination defines when contamination exists. It is the shipper's responsibility to determine if the contamination exists in

sufficient quantity to exceed both limits in 49 CFR 173.436 before classifying as radioactive (class 7) material.

**\* If a shipment is consigned to different consignees, what is the consignment activity?**

**Reference # 13-0080**

The activity of the consignment will be the total activity on the conveyance. While the packages are destined for different consignees, all of the packages are offered for transport from the same consignor at the same time, on the same conveyance. Please note it is not acceptable to create separate shipping documents and to declare it as separate consignments in order to avoid compliance with the HMR (49 CFR Parts 107-180).

**\* Does naturally occurring radioactive material (NORM) contained in an industrial waste product from the drilling and extraction processes used by the**

**oil and gas exploration industry qualify for the natural material and ores containing NORM exception in 49 CFR 173.401(b)(4)?**

**Reference # 13-0157**

No, fracking water is not a natural material nor is the radionuclide-containing solidified sludge from the fracking water collection pit or the radionuclide-containing filter cake from treatment and recycling of the fracking water. Thus, the exception in 49 CFR 173.401(b)(4) does not apply.

To access any DOT letters of interpretation, go to: <http://www.phmsa.dot.gov/hazmat> Then, click on: "Interpretations" Next, you can search by entering the reference number in the search box or search by the applicable regulatory section number, or search by the published date.

## Recent Lessons Learned, Industry Events, Operating Experiences



Can you identify at least 2 issues with this label? Label information must be legibly printed (manual or mechanical) using a durable weather resistant means of marking per 49 CFR 172.403(g). Maybe hard to see in this picture, but the printing in the contents and activity blocks are smudged and faded upon receipt. Also, be careful with extra information written on a label beyond what is required that may cause confusion,

like "0448" written between the outer and inner border of this label. Manufacturers are allowed to print their information in this area of the label per 49 CFR 172.407(e).

**Class Schedule June – August 2016**

Course	Date	Location
Hazardous Material General Awareness Transportation Training	June 1, 2016	Richland, WA
Federal Motor Carrier Safety Regulations for Drivers	June 2, 2016	Richland, WA
Load Securement for Drivers and Traffic Personnel	June 7, 2016	Richland, WA
DOT/NRC Radioactive Waste Packaging, Transportation and Disposal Training	June 6-9, 2016	Mt. Pleasant, SC
Hazardous Materials Drivers Training	June 9, 2016	Richland, WA
Air Transport of Radioactive Materials Training	June 10, 2016	Mt. Pleasant, SC
Federal Motor Carrier Safety Regulations for Managers & Supervisors	June 14-15, 2016	Richland, WA
IATA: Transportation of Dangerous Goods by Air Shipper Certification Training	June 14-16, 2016	Las Vegas, NV
Reasonable Suspicion Training for Supervisors	June 16, 2016	Richland, WA
Advanced Mixed Waste Shipper Certification Training	June 20-23, 2016	Las Vegas, NV
Advanced Mixed Waste Shipper Certification Training	June 27-30, 2016	Richland, WA
Hazardous Material General Awareness Transportation Training	June 28, 2016	Richland, WA
Hazardous Material General Awareness Transportation Training	June 30, 2016	Richland, WA
Hazardous Material General Awareness Transportation Training	July 6, 2016	Richland, WA
Basic Level Transportation Training – Module 1 – Basic Hazardous Material	July 11-12, 2016	Albuquerque, NM
Basic Level Transportation Training – Module 2 – Basic Hazardous Waste	July 13, 2016	Albuquerque, NM
Basic Level Transportation Training – Module 3 – Basic Radioactive Material	July 13-14, 2016	Albuquerque, NM
*Attend all three modules consecutively for \$1,550.00 (savings of \$600.00)		
DOT/NRC/EPA Hazardous Waste/Mixed Waste Packaging, Transportation and Disposal	July 12-15, 2016	Clive, UT
Basic Level Transportation Training – Module 1 – Basic Hazardous Material	July 18-19, 2016	Las Vegas, NV
Basic Level Transportation Training – Module 2 – Basic Hazardous Waste	July 20, 2016	Las Vegas, NV
Basic Level Transportation Training – Module 3 – Basic Radioactive Material	July 20-21, 2016	Las Vegas, NV
*Attend all three modules consecutively for \$1,550.00 (savings of \$600.00)		
Hazardous Materials Drivers Training	July 19, 2016	Richland, WA
Highway Route Control Quantity (HRCQ)	July 20, 2016	Richland, WA
Load Securement for Drivers and Traffic Personnel	July 21, 2016	Richland, WA
Basic Level Transportation Training – Module 1 – Basic Hazardous Material	July 25-26, 2016	Richland, WA
Basic Level Transportation Training – Module 2 – Basic Hazardous Waste	July 27, 2016	Richland, WA
Basic Level Transportation Training – Module 3 – Basic Radioactive Material	July 27-28, 2016	Richland, WA
*Attend all three modules consecutively for \$1,550.00 (savings of \$600.00)		
General Packaging Requirements for the Transport of HazMat	July 26, 2016	Richland, WA
Radioactive Material Packaging Training	July 27, 2016	Richland, WA
Advanced Hazardous Material Shipper Certification Training	August 2-3, 2016	Richland, WA
Advanced Radioactive Material Shipper Certification Training	August 2-4, 2016	Richland, WA
DOT/NRC Radioactive Waste Packaging, Transportation and Disposal Training	August 1-4, 2016	Orlando, FL
Air Transport of Radioactive Materials Training	August 5, 2016	Orlando, FL
Federal Motor Carrier Safety Regulations for Drivers	August 9, 2016	Richland, WA
Advanced Hazardous Material Shipper Certification Training	August 9-10, 2016	Albuquerque, NM
Explosives Training for Shippers	August 11, 2016	Albuquerque, NM
Hazardous Materials Drivers Training	August 11, 2016	Richland, WA
Hazardous Material General Awareness Transportation Training	August 17, 2016	Richland, WA
Advanced Hazardous Material Shipper Certification Training	August 23-24, 2016	Las Vegas, NV
Explosives Training for Shippers	August 25, 2016	Las Vegas, NV
Load Securement for Drivers and Traffic Personnel	August 25, 2016	Richland, WA

\*\*Class dates and locations are subject to change\*\*



## Online Training

Atkins offers many courses online. Online training is a cost effective alternative to classroom training. It is self-paced and flexible, allowing the user to complete the course at his or her convenience. Training materials and references are accessed from the website.

Upon successful completion of your online training and receipt of payment, Atkins will provide a certificate indicating that you have completed the training.

### How to Get Started:

- Call or e-mail a contact listed below.
- Provide payment (check or credit card).
- Receive an access code.

### What you Will Need:

- Access to a computer.
- Ability to print PDF files.



### Contacts:

Jennifer Keszler (509) 375-9507  
[Jennifer.Keszler@atkinglobal.com](mailto:Jennifer.Keszler@atkinglobal.com)

Merrie Schilperoort (509) 375-9504  
[Merrie.Schilperoort@atkinglobal.com](mailto:Merrie.Schilperoort@atkinglobal.com)

Nancy Strong (803) 758-1882  
[Nancy.Strong@atkinglobal.com](mailto:Nancy.Strong@atkinglobal.com)

Please visit our web site at [www.atkinglobal.com/energytraining](http://www.atkinglobal.com/energytraining) for course descriptions, pricing, and registration forms.

### Available Courses

Air Transport of Radioactive Materials – \$525

FMCSR for Drivers – \$425

FMCSR for Managers and Supervisors – \$650

Hazardous Material General Awareness Transportation Training – \$425

General Packaging – \$425

Hazardous Material Drivers Training – \$325

HRCQ for Drivers – \$325

Load Securement for Drivers and Traffic Personnel – \$325

Transportation of Radioactive Materials for Drivers and Carriers – \$450

Basic IATA: Transport of Dangerous Goods by Air – \$975 (includes current IATA Dangerous Goods Regulations) – \$600 (without regulations)

**(Just Released!)**

NRC/DOT Radioactive Waste Packaging, Transportation and Disposal Training – \$1,295

Radiological Controls Technician (RCT) – \$425